



Flow control valves and one-way flow control valves

Technical data – Standard flow control valve with female thread

Ordering data								
Design	Screw-in thread	Connecting thread	One-way flow control function for exhaust air		One-way flow control function for supply air		Flow control function, acting at both sides	
			Part No.	Type	Part No.	Type	Part No.	Type
Female thread, elbow outlet, slotted head screw								
	M5	M5	151 160	GRLA-M5-B	151 183	GRLZ-M5-B	151 181	GRLO-M5-B
	G1/8	G1/8	151 165	GRLA-1/8-B	151 188	GRLZ-1/8-B	-	-
	G1/4	G1/4	151 172	GRLA-1/4-B	151 195	GRLZ-1/4-B	-	-
	G3/8	G3/8	151 178	GRLA-3/8-B	-	-	-	-
	G1/2	G1/2	151 179	GRLA-1/2-B	-	-	-	-
	G3/4	G3/4	151 180	GRLA-3/4-B	-	-	-	-
Female thread, elbow outlet, knurled screw								
	M5	M5	151 163	GRLA-M5-RS-B	151 186	GRLZ-M5-RS-B	-	-
	G1/8	G1/8	151 169	GRLA-1/8-RS-B	151 192	GRLZ-1/8-RS-B	-	-
	G1/4	G1/4	151 175	GRLA-1/4-RS-B	151 198	GRLZ-1/4-RS-B	-	-
Female thread, elbow outlet, slotted head screw								
Free of copper, PTFE and silicone								
	M5	M5	165 663	GRLA-M5-B-CT	-	-	-	-
	G1/8	G1/8	165 654	GRLA-1/8-B-CT	-	-	-	-
	G1/4	G1/4	165 648	GRLA-1/4-B-CT	-	-	-	-
	G3/8	G3/8	165 662	GRLA-3/8-B-CT	-	-	-	-
	G1/2	G1/2	165 647	GRLA-1/2-B-CT	-	-	-	-
	G3/4	G3/4	165 661	GRLA-3/4-B-CT	-	-	-	-

Valves with threaded connections G1/4

Technical data – 5/2-way valves

FESTO

Dimensions

Download CAD data → www.festo.com

Hand lever valve H

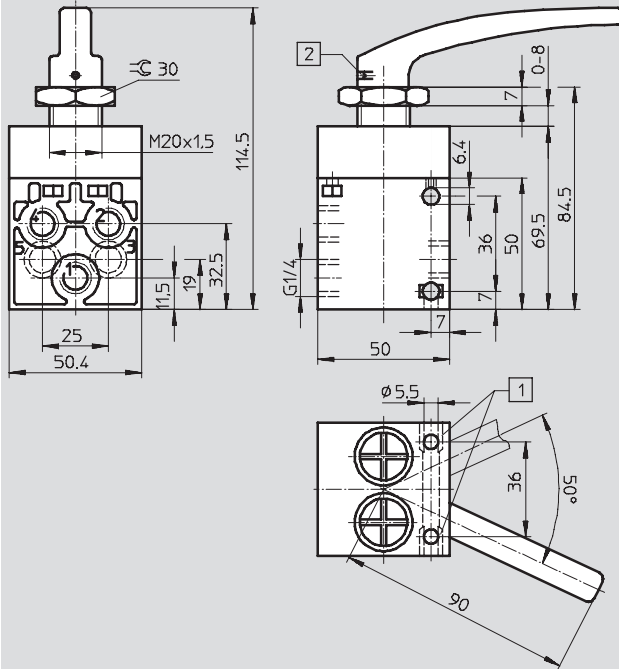



1 For hex nut M5 DIN 934

2 Locking screw

Valves with threaded connections G1/4

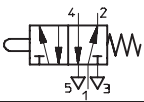
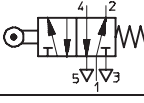
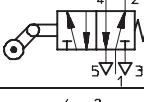
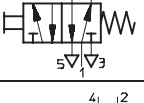
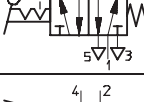
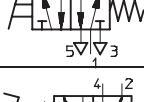
Technical data – 5/2-way valves

Ordering data			
Circuit symbol	Actuation type	Part No.	Type
	Stem actuated valve	6 809	V-5-1/4-B
	Roller lever valve	8 996	R-5-1/4-B
	Roller lever valve with idle return	8 993	L-5-1/4-B
	Finger lever valve	8 994	TH-5-1/4-B
	Hand lever valve	8 995	H-5-1/4-B
	Foot valve	8 992	F-5-1/4-B
	Foot valve with mechanical detent	8 997	FP-5-1/4-B
		526 985	FPB-5-1/4

Ordering data – Wearing parts kits			
	Part No.	Type	
For 5/2-way valves ¹⁾	104 502	V-5-1/4-B	

1) not for foot valves F, FP, FPB

Standard cylinders DNC, ISO 15552

Accessories

FESTO

Swivel flange

SNCB/SNCB-...-R3

Material:

SNCB: Die-cast aluminium

SNCB-...-R3: Die-cast aluminium with protective coating, high corrosion protection

Free of copper, PTFE and silicone

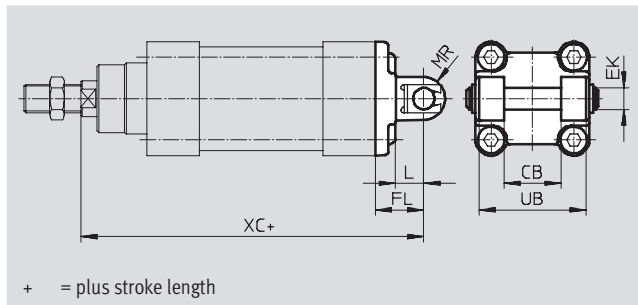

+ = plus stroke length

Dimensions and ordering data								
For \varnothing	CB	EK	FL	L	MR	UB	XC	
[mm]	H14	\varnothing e8	± 0.2			h14		KP
32	26	10	22	13	8.5	45	142	187
40	28	12	25	16	12	52	160	213
50	32	12	27	16	12	60	170	237
63	40	16	32	21	16	70	190	266
80	50	16	36	22	16	90	210	305
100	60	20	41	27	20	110	230	328
125	70	25	50	30	25	130	275	400

For \varnothing	Basic version				Variant R3 – High corrosion protection			
	CRC ¹⁾	Weight [g]	Part No.	Type	CRC ¹⁾	Weight [g]	Part No.	Type
[mm]								
32	2	100	174 390	SNCB-32	3	100	176 944	SNCB-32-R3
40	2	150	174 391	SNCB-40	3	150	176 945	SNCB-40-R3
50	2	225	174 392	SNCB-50	3	225	176 946	SNCB-50-R3
63	2	365	174 393	SNCB-63	3	365	176 947	SNCB-63-R3
80	2	610	174 394	SNCB-80	3	610	176 948	SNCB-80-R3
100	2	925	174 395	SNCB-100	3	925	176 949	SNCB-100-R3
125	2	1,785	174 396	SNCB-125	3	1,785	176 950	SNCB-125-R3

1) Corrosion resistance class 2 as per Festo standard 940 070

Components subject to moderate corrosion stress. Externally visible parts with primarily decorative surface requirements which are in direct contact with a normal industrial environment or media such as coolants or lubricating agents.

Corrosion resistance class 3 as per Festo standard 940 070

Components requiring higher corrosion resistance. External visible parts in direct contact with industrial atmospheres or media such as solvents and cleaning agents, with a predominantly functional requirement for the surface.

Standard cylinders DNC, ISO 15552

Accessories

Swivel flange SNC

Material:
Die-cast aluminium

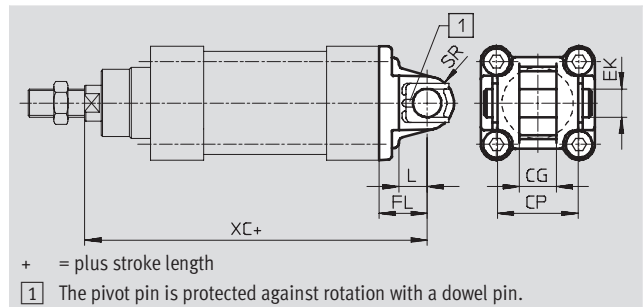

Dimensions and ordering data												
For Ø	CG	CP	EK	FL	L	SR	XC		CRC ¹⁾	Weight	Part No.	Type
[mm]	H14	h14	Ø H9	±0.2				KP		[g]		
32	14	34	10	22	13	10	142	187	2	90	174 383	SNC-32
40	16	40	12	25	16	12	160	213	2	120	174 384	SNC-40
50	21	45	16	27	16	12	170	237	2	240	174 385	SNC-50
63	21	51	16	32	21	16	190	266	2	320	174 386	SNC-63
80	25	65	20	36	22	16	210	305	2	625	174 387	SNC-80
100	25	75	20	41	27	20	230	328	2	830	174 388	SNC-100
125	37	97	30	50	30	25	275	400	2	1,785	174 389	SNC-125

1) Corrosion resistance class 2 as per Festo standard 940 070
Components subject to moderate corrosion stress. Externally visible parts with primarily decorative surface requirements which are in direct contact with a normal industrial environment or media such as coolants or lubricating agents.

Standard cylinders DNC, ISO 15552



Accessories

Trunnion mounting kit ZNCM for basic version DNC

The mounting kit can be attached at any position along the profile barrel of a cylinder.

Material:
Tempered steel

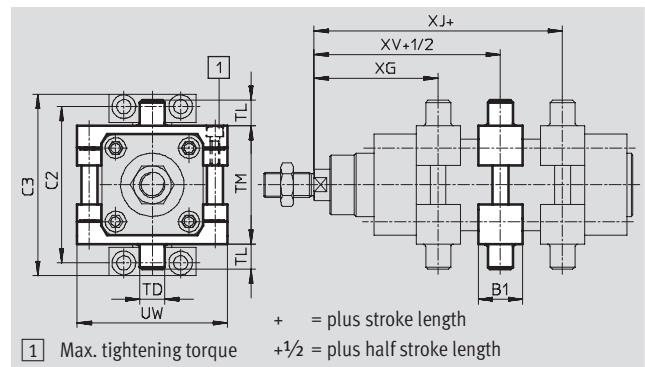

for DNC-KP

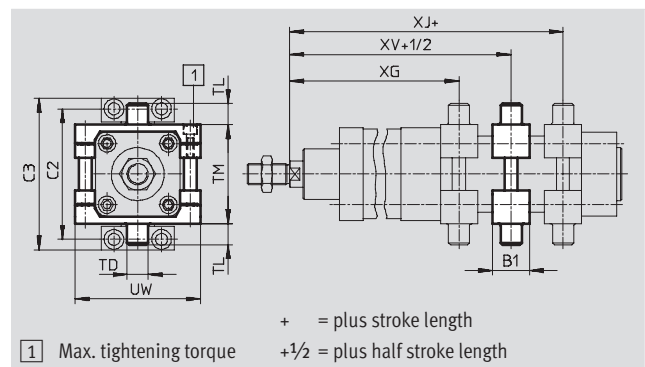

Dimensions and ordering data										
For \varnothing [mm]	B1	C2	C3	TD \varnothing e9	TL	TM	UW	XG		
								Basic version	KP	
32	30	71	86	12	12	50	65	66.1	111.1	
40	32	87	105	16	16	63	75	75.6	128.6	
50	34	99	117	16	16	75	95	83.6	150.6	
63	41	116	136	20	20	90	105	93.1	169.1	
80	44	136	156	20	20	110	130	103.9	198.9	
100	48	164	189	25	25	132	145	113.8	211.8	
125	50	192	217	25	25	160	175	134.7	259.7	

For \varnothing [mm]	XJ		XV		Max. tightening torque [Nm]	CRC ¹⁾	Weight [g]	Part No.	Type
		KP		KP					
32	79.9	124.9	73	118	4+1	2	210	163 525	ZNCM-32
40	89.4	142.4	82.5	135.5	8+1	2	385	163 526	ZNCM-40
50	96.4	163.4	90	157	8+2	2	595	163 527	ZNCM-50
63	101.9	177.9	97.5	173.5	18+2	2	890	163 528	ZNCM-63
80	116.1	211.1	110	205	28+2	2	1,450	163 529	ZNCM-80
100	126.2	224.2	120	218	28+2	2	2,045	163 530	ZNCM-100
125	155.3	280.3	145	270	40+2	2	2,940	163 531	ZNCM-125

1) Corrosion resistance class 2 as per Festo standard 940 070
Components subject to moderate corrosion stress. Externally visible parts with primarily decorative surface requirements which are in direct contact with a normal industrial environment or media such as coolants or lubricating agents.

Trunnion supports LNZG/CRLNZG

Technical data

Trunnion support LNZG

Material:

Trunnion support:

32 ... 125: Anodised aluminium

160 ... 320: Galvanised steel

Plain bearing:

32 ... 200: Plastic

250 ... 320: Sintered bronze

Free of copper, PTFE and silicone

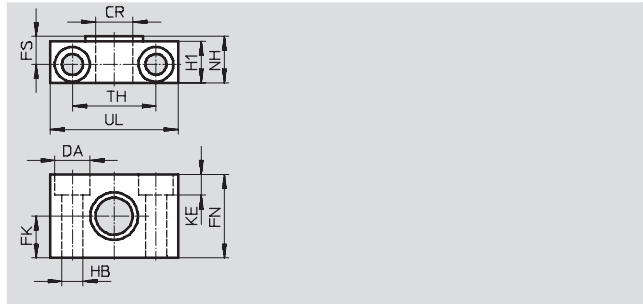
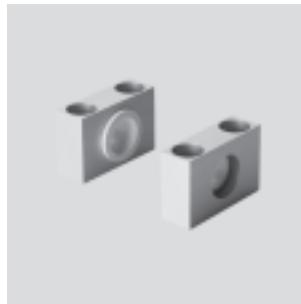

Dimensions and ordering data															
For Ø	CR	DA	FK	FN	FS	H1	HB	KE	NH	TH	UL	CRC ¹⁾	Weight	Part No.	Type
[mm]	Ø	Ø	Ø				Ø						[g]		
32	12 D11	11	15 ±0.1	30	10.5	15	6.6	6.8	18	32 ±0.2	46	2	125	32 959	LNZG-32
40/50	16 D11	15	18 ±0.1	36	12	18	9	9	21	36 ±0.2	55	2	400	32 960	LNZG-40/50
63/80	20 D11	18	20 ±0.1	40	13	20	11	11	23	42 ±0.2	65	2	480	32 961	LNZG-63/80
100/125	25 D11	20	25 ±0.1	50	16	24.5	14	13	28.5	50 ±0.2	75	2	960	32 962	LNZG-100/125
160/200	32 D11	26	30 ±0.2	60	22.5	36	18	17	40	60 ±0.3	92	2	1965	35 780	LNZG-160/200
250	40 G7	33	35 ±0.2	70	27.5	45	22	21.5	50	90 ±0.3	140	2	5500	157 516	LNZG-250
320	50 G7	40	40 ±0.2	80	32.5	55	26	21.5	60	100 ±0.3	150	2	6580	157 517	LNZG-320

1) Corrosion resistance class 2 according to Festo standard 940 070

Components requiring moderate corrosion resistance. Externally visible parts with primarily decorative surface requirements which are in direct contact with a surrounding industrial atmosphere or media such as cooling or lubricating agents.

Trunnion support CRLNZG, stainless steel

Material:

High-alloy steel

Free of copper, PTFE and silicone

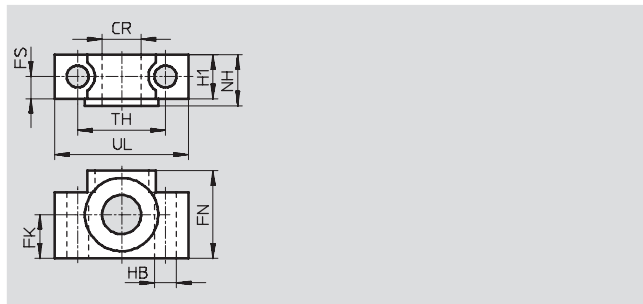
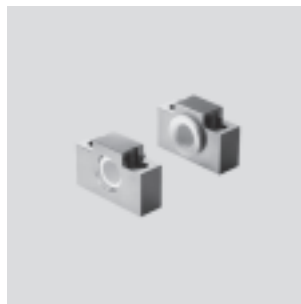

Dimensions and ordering data															
For Ø	CR	FK	FN	FS	H1	HB	NH	TH	UL	CRC ¹⁾	Weight	Part No.	Type		
[mm]	Ø	Ø				Ø					[g]				
32	12	15	30	10.5	15	6.6	18	32	46	4	200	161 874	CRLNZG-32		
40/50	16	18	36	12	18	9	21	36	55	4	330	161 875	CRLNZG-40/50		
63/80	20	20	40	13	20	11	23	42	65	4	440	161 876	CRLNZG-63/80		
100	25	25	50	16	24.5	14	28.5	50	75	4	740	161 877	CRLNZG-100		

1) Corrosion resistance class 4 according to Festo standard 940 070

Components requiring higher corrosion resistance. Parts used with aggressive media, e.g. food or chemical industry. These applications should be supported with special tests with the media if required.

Clevis feet LBG

Technical data

Clevis foot LBG

The pivot pin is secured against rotation with a dowel pin.

Material:

Nodular graphite cast iron
Free of copper, PTFE and silicone

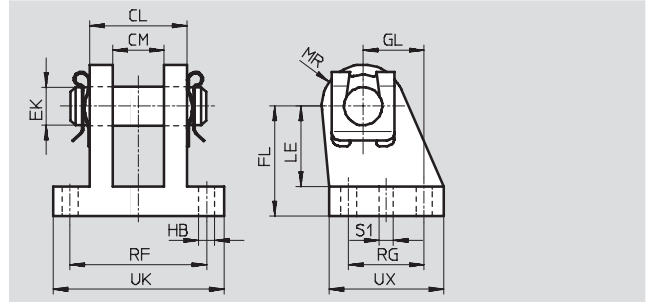

Dimensions and ordering data																	
For \varnothing	CL	CM	EK	FL	GL	HB	LE	MR	RF	RG	S1	UK	UX	CRC ¹⁾	Weight	Part No.	Type
[mm]			\varnothing			\varnothing					\varnothing				[g]		
32	28	14.1	10	32	16	6.8	24	12	42	20	4.8	56	36	2	220	31 761	LBG-32
40	30	16.1	12	36	20	6.8	26	14	44	26	5.8	58	41.5	2	300	31 762	LBG-40
50	40	21.1	16	45	25	9.2	33	15	56	31	5.8	70	47	2	540	31 763	LBG-50
63	40	21.1	16	50	25	9	38	17	56	31	7.8	70	47	2	580	31 764	LBG-63
80	50	25.1	20	63	30	11	49	18	70	36	7.8	89	57	2	1050	31 765	LBG-80
100	50	25.1	20	71	41	11	56	22	70	46	9.8	89	67.5	2	1375	31 766	LBG-100
125	80	37.2	30	90	60	14	70	26	106	70	11.8	128	96	2	4140	31 767	LBG-125

1) Corrosion resistance class 2 according to Festo standard 940 070

Components requiring moderate corrosion resistance. Externally visible parts with primarily decorative surface requirements which are in direct contact with a surrounding industrial atmosphere or media such as cooling or lubricating agents.

Piston rod attachments



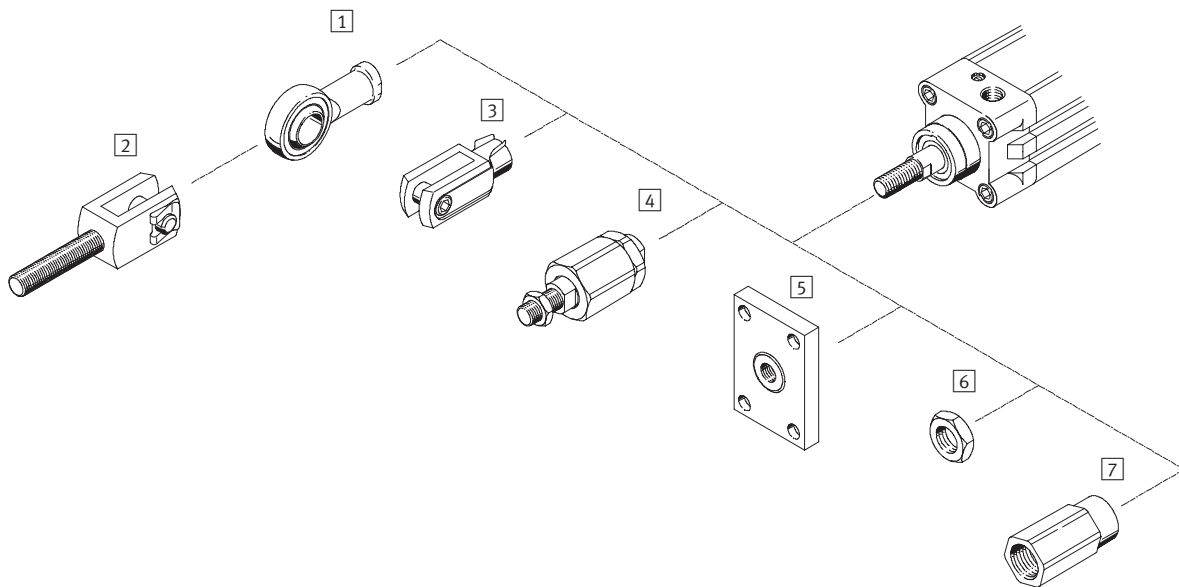

Peripherals overview





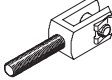

Mounting attachments and accessories		Brief description
1	Rod eye SGS Rod eye CRSGS	Rod eyes are maintenance-free due to the combination of steel and PTFE-bronze material in the swivel bearing. Corresponds to DIN ISO 12 240-4 dimensional series K. Corrosion and acid-resistant design. Corresponds to DIN ISO 12 240-4 dimensional series K.
2	Rod clevis SGA	Rod clevises are used in combination with the rod eye SGS for spherical connection of cylinders.
3	Rod clevis SG Rod clevis CRSG	This rod clevis is fitted to the threaded end of the piston rod and permits a swivelling movement of the cylinder in one plane. Corresponds to DIN ISO 8140 or DIN 71 752 Corrosion and acid-resistant design. Corresponds to DIN ISO 8140 or DIN 71 752
4	Self-aligning rod coupler FK	Rod couplers link the piston rod end of all cylinder types to the machine parts to be moved. This compensates for radial and angular deviations (misalignment).
5	Coupling piece KSG Coupling piece KSZ	Coupling pieces link the piston rod end of all cylinder types to the machine parts to be moved. They compensate radial misalignments up to ± 1 mm. For cylinders with non-rotating piston rods. With this coupling piece, a cylinder can be connected with positional stability to the component being moved in order to compensate for radial deviation.
6	Hex nut MSK	Based on and/or corresponds to DIN EN ISO 8675.
7	Adapter AD	Specially for through, hollow piston rods, e.g. for connecting vacuum generators.

Piston rod attachments

Product range overview

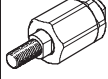
Piston rod attachments						
Piston rod thread		Rod eye		Rod clevis		
Male	Female	SGS-...	CRSGS-...	SGA-... ¹⁾	SG-...	CRSG-...
						
M4		■	-	-	■	-
M6		■	■	-	■	■
M8		■	■	-	■	■
M10		■	-	-	■	-
M10x1.25		■	■	■	■	■
M12		■	-	■	■	-
M12x1.25		■	■	■	■	■
M16		■	-	■	■	-
M16x1.5		■	■	■	■	■
M20x1.5		■	■	■	■	■
M27x2		■	■	■	■	■
M36x2		■	-	-	■	-
M42x2		■	-	-	■	-
M48x2		■	-	-	■	-
Technical data → Page/Internet		1 / 10.3-4	1 / 10.3-5	1 / 10.3-6	1 / 10.3-7	1 / 10.3-8

1) Only to be attached to the piston rod in conjunction with the rod eye SGS.

Piston rod attachments						
Piston rod thread		Self-aligning rod coupler	Coupling piece		Hex nut	Adapter
Male	Female	FK-...	KSG-...	KSZ-...	MSK-...	AD-...
						
M4		■	-	-	-	-
M6		■	-	■	-	■
M8		■	-	■	-	■
M10		■	-	-	-	-
M10x1.25		■	■	■	■	■
M12		■	-	-	-	-
M12x1.25		■	■	■	■	■
M16		■	-	-	-	-
M16x1.5		■	■	■	■	-
M20x1.5		■	■	■	-	-
M27x2		■	■	-	-	-
M36x2		■	-	-	-	-
M42x2		-	-	-	-	-
M48x2		-	-	-	-	-
	M4	■	-	-	-	-
	M5	■	-	-	-	-
	M6	■	-	-	-	-
	M8	■	-	-	-	-
	M10	■	-	-	-	-
	M12	■	-	-	-	-
Technical data → Page/Internet		1 / 10.3-9	1 / 10.3-10	1 / 10.3-11	1 / 10.3-12	1 / 10.3-13

Rod eyes SGS

Technical data

FESTO

Rod eye SGS

Scope of delivery:

1 rod eye, 1 hex nut to DIN 439

Material:

Galvanised steel

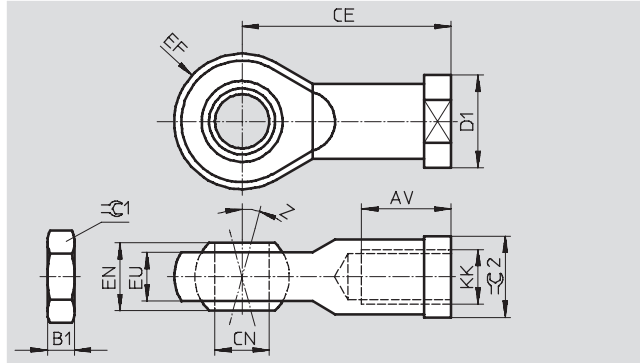

Dimensions and ordering data

KK	AV	B1	CE	CN Ø H7	D1 Ø	EF ±0.5	EN	EU
M4	10 -2	2.2	27	5	11	9	8	6
M6	12 -2	3.2	30	6	13	10	9	6.8
M8	16 -2	4	36	8	16	12	12	9
M10	20 -2	5	43	10	19	14	14	10.5
M10x1.25								
M12	22 -2	6	50	12	22	16	16	12
M12x1.25								
M16	28 -2	8	64	16	27	21	21	15
M16x1.5								
M20x1.5	33 -2	10	77	20	34	25	25	18
M27x2	51 -2	13.5	110	30	50	35	37	25
M36x2	56 +2	18	125	35	58	40	43	28
M42x2	60 +2	21	142	40	65	45	49	33
M48x2	65 +2	24	160	50	75	58	60	45

KK	Z [°]	≈C1	≈C2	DIN ISO 12 240-4 dimensional series K	CRC ¹⁾	Weight [g]	Part No.	Type
M4	13	7	9	–	2	17	9 253	SGS-M4
M6	13	10	11	■	2	25	9 254	SGS-M6
M8	13	13	14	■	2	45	9 255	SGS-M8
M10	13	17	17	■	2	70	9 256	SGS-M10
M10x1.25				–	2	70	9 261	SGS-M10x1,25
M12	13	19	19	■	2	105	9 257	SGS-M12
M12x1.25				–	2	105	9 262	SGS-M12x1,25
M16	15	24	22	■	2	210	9 258	SGS-M16
M16x1.5				–	2	210	9 263	SGS-M16x1,5
M20x1.5	15	30	30	■	2	380	9 264	SGS-M20x1,5
M27x2	15	41	41	–	2	1,300	10 774	SGS-M27x2
M36x2	15	55	50	■	2	1,825	10 775	SGS-M36x2
M42x2	15	65	55	■	2	2,780	10 776	SGS-M42x2
M48x2	12	75	65	■	2	5,215	10 777	SGS-M48x2





1) Corrosion resistance class 2 according to Festo standard 940 070

Components requiring moderate corrosion resistance. Externally visible parts with primarily decorative surface requirements which are in direct contact with a surrounding industrial atmosphere or media such as cooling or lubricating agents

Standard cylinders DNC, ISO 15552

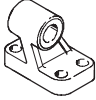
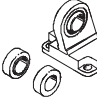
Accessories

FESTO

Ordering data – Mounting attachments				Technical data → Internet: clevis foot			
Designation	For Ø	Part No.	Type	Designation	For Ø	Part No.	Type
Clevis foot LNG				Clevis foot LSN			
	32	33 890	LNG-32		32	5 561	LSN-32
	40	33 891	LNG-40		40	5 562	LSN-40
	50	33 892	LNG-50		50	5 563	LSN-50
	63	33 893	LNG-63		63	5 564	LSN-63
	80	33 894	LNG-80		80	5 565	LSN-80
	100	33 895	LNG-100		100	5 566	LSN-100
	125	33 896	LNG-125		125	6 987	LSN-125
Clevis foot LSNG				Clevis foot for welding LSNSG			
	32	31 740	LSNG-32		32	31 747	LSNSG-32
	40	31 741	LSNG-40		40	31 748	LSNSG-40
	50	31 742	LSNG-50		50	31 749	LSNSG-50
	63	31 743	LSNG-63		63	31 750	LSNSG-63
	80	31 744	LSNG-80		80	31 751	LSNSG-80
	100	31 745	LSNG-100		100	31 752	LSNSG-100
	125	31 746	LSNG-125		125	31 753	LSNSG-125
Clevis foot LBG				Right-angle clevis foot LQG			
	32	31 761	LBG-32		32	31 768	LQG-32
	40	31 762	LBG-40		40	31 769	LQG-40
	50	31 763	LBG-50		50	31 770	LQG-50
	63	31 764	LBG-63		63	31 771	LQG-63
	80	31 765	LBG-80		80	31 772	LQG-80
	100	31 766	LBG-100		100	31 773	LQG-100
	125	31 767	LBG-125		125	31 774	LQG-125

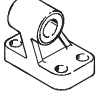
Ordering data – Mounting attachments, corrosion-resistant				Technical data → Internet: crlng			
Designation	For Ø	Part No.	Type	Designation	For Ø	Part No.	Type
Clevis foot CRLNG				Clevis foot CRLNG			
	32			32		161 840	CRLNG-32
	40			40		161 841	CRLNG-40
	50			50		161 842	CRLNG-50
	63			63		161 843	CRLNG-63
	80			80		161 844	CRLNG-80
	100			100		161 845	CRLNG-100
	125			125		176 951	CRLNG-125

Standard cylinders DNC, ISO 15552

Product range overview

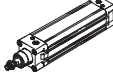
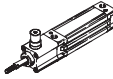
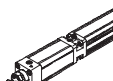
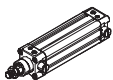
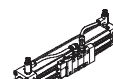
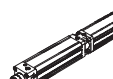

Function	Design	Type	Piston Ø	Stroke	Position sensing	Protection against rotation	Through/hollow piston rod	Extended male piston rod thread	Female piston rod thread	Special piston rod thread	
			[mm]	[mm]							A
Double-acting	Basic version										
		DNC	32, 40, 50, 63, 80, 100, 125	25, 40, 50, 80, 100, 125, 160, 200, 250, 320, 400, 500	10 ... 2,000	■	■	■	■	■	■
	Standard hole pattern, with clamping unit										
		DNC-KP	32, 40, 50, 63, 80, 100, 125	–	10 ... 2,000	■	■	■ S2	■	■	■
		DNCKE	40, 63, 100	–	10 ... 2,000	■	–	–	–	–	–
	Standard hole pattern, with end-position locking										
		DNC-...-EL	32, 40, 50, 63, 80, 100	–	10 ... 2,000	■	–	■ S2	■	■	■
	Standard hole pattern, cylinder/valve combination										
		DNC-V1 ... V6	32, 40, 50, 63, 80, 100	–	100 ... 2,000	■	■	■	■	■	■
	Standard hole pattern, tandem cylinder										
	DNCT	32, 40, 50, 63, 80, 100, 125	–	2 ... 500 3 ... 500	■	–	–	–	–	–	

Standard cylinders DNC, ISO 15552

Product range overview

Type	Special spanner flats	Extended piston rod	Smooth anodised piston rod	Heat-resistant seals to max. 120 °C	Slow speed (constant motion)	Low friction	Free of copper, PTFE and silicone	High corrosion protection	Dust protection	Low temperature	Cylinder/valve combination	→ Page/Internet
	K7	K8	K10	S6	S10	S11	CT	R3	R8	TT	V1 ... V6	
Basic version												
DNC	■	■	■	■	■	■	■	■	■	■	-	9
Standard hole pattern, with clamping unit												
DNC-KP	■	■	-	-	-	-	-	-	-	-	■	23
DNCKE	-	-	-	-	-	-	-	-	-	-	-	dncke
Standard hole pattern, with end-position locking												
DNC...-EL	-	■	-	-	-	-	-	-	-	-	-	31
Standard hole pattern, cylinder/valve combination												
DNC-V1 ... V6	■	■	■	-	■	■	-	-	■	-	■	38
Standard hole pattern, tandem cylinder												
DNCT	-	-	-	■	-	-	-	-	-	-	-	dnct

Standard cylinders DNC, ISO 15552

Peripherals overview

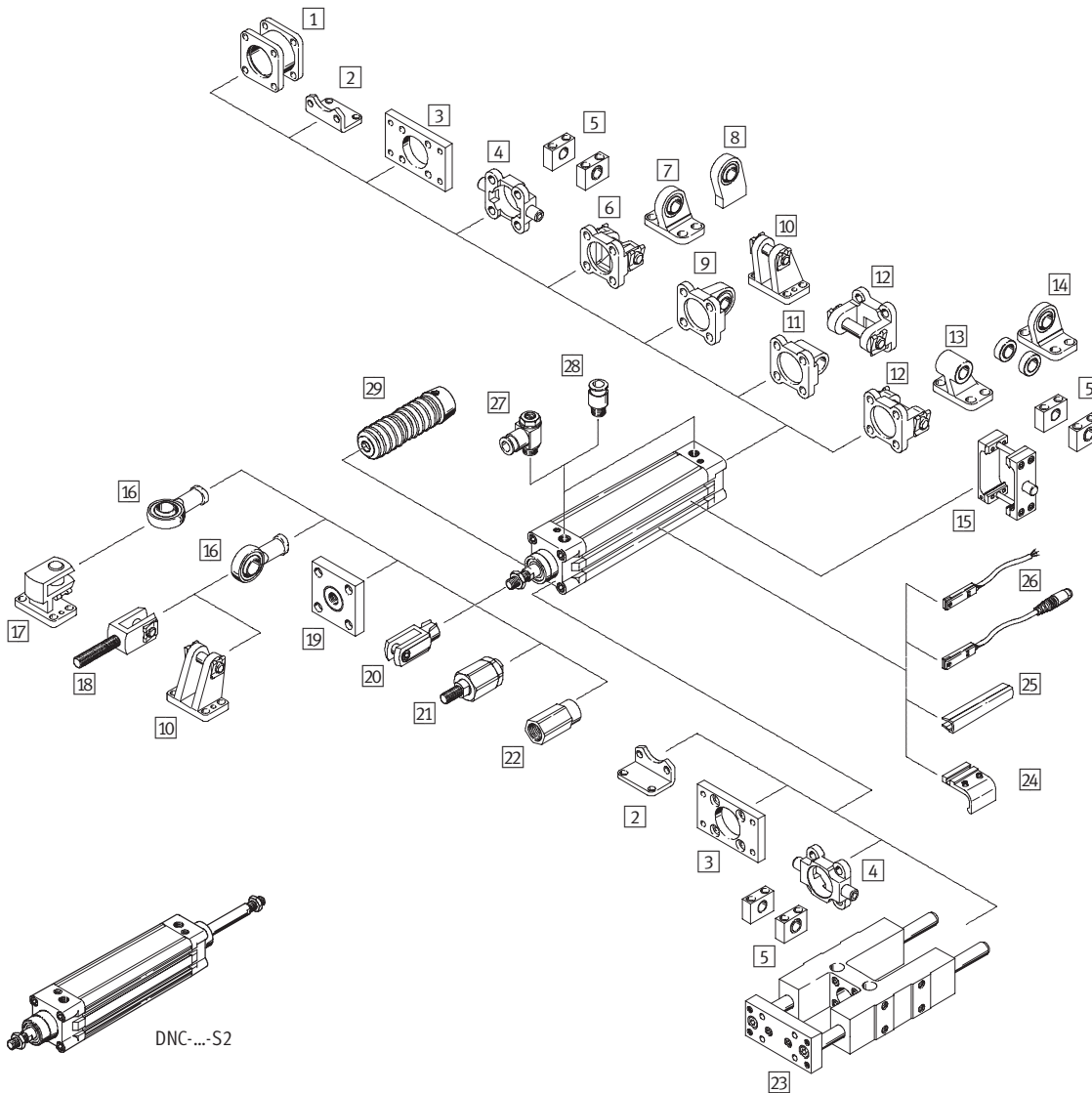

DNC-...-S2

Mounting attachments and accessories						
	Brief description	DNC				→ Page/ Internet
		Basic version	KP	EL	V1 ... V6	
1	Multi-position kit DPNC	■ ¹⁾	■	■	■ ¹⁾	47
2	Foot mounting HNC/CRHNC	■	■	■	■	48
3	Flange mounting FNC/CRFNG	■	■	■	■	49
4	Trunnion flange ZNCF/CRZNG	■	■	■	■	50
5	Trunnion support LNZG/CRLNZG	■	■	■	■	52
6	Swivel flange SNC	■ ¹⁾	■ ¹⁾	■	■ ¹⁾	53
7	Clevis foot LSNG	■ ¹⁾	■ ¹⁾	■	■ ¹⁾	56
8	Clevis foot LSNSG	■ ¹⁾	■ ¹⁾	■	■ ¹⁾	56

Standard cylinders DNC, ISO 15552

Peripherals overview

FESTO

Mounting attachments and accessories							
	Brief description	DNC				→ Page/ Internet	
		Basic version	KP	EL	V1 ... V6		
9	Swivel flange SNCS	With spherical bearing for end caps	■ ¹⁾	■ ¹⁾	■	■ ¹⁾	55
10	Clevis foot LBG	–	■ ¹⁾	■	■	■ ¹⁾	56
11	Swivel flange SNCL	For end caps	■ ¹⁾	■ ¹⁾	■	■ ¹⁾	55
12	Swivel flange SNCB/SNCB-...-R3	For end caps	■ ¹⁾	■ ¹⁾	■	■ ¹⁾	54
13	Clevis foot LNG/CRLNG	–	■ ¹⁾	■ ¹⁾	■	■ ¹⁾	56
14	Clevis foot LSN	With spherical bearing	■ ¹⁾	■ ¹⁾	■	■ ¹⁾	56
15	Trunnion mounting kit ZNCM	For mounting anywhere along the cylinder profile barrel	■	■	■	■	51
16	Rod eye SGS/CRSGS	With spherical bearing	■	■	■	■	57
17	Right-angle clevis foot LQG	–	■	■	■	■	56
18	Rod clevis SGA	With male thread	■	■	■	■	57
19	Coupling piece KSG	To compensate for radial deviations	■	■	■	■	57
	Coupling piece KSZ	For cylinders with a non-rotating piston rod to compensate for radial deviations	■	■	■	■	57
20	Rod clevis SG/CRSG	Permits a swivelling movement of the cylinder in one plane	■	■	■	■	57
21	Self-aligning rod coupler FK	For compensating radial and angular deviations	■	■	■	■	57
22	Adapter AD	For fitting a suction cup on a hollow cylinder piston rod	■	–	–	■	57
23	Guide unit FENG	For protecting standard cylinders against rotation at high torque loads	■	■ ∅ 50 and above	–	–	62
24	Mounting kit SMB-8-FENG	For attaching proximity sensor SMT-8 to cylinders in combination with guide unit FENG	■ ²⁾	■ ∅ 50 and above	■	–	62
25	Slot cover ABP-5-S	For protecting the sensor cables and keeping dirt out of the sensor slots	■	■	■	■	63
26	Proximity sensor SME/SMT-8	Can be integrated in the cylinder profile barrel	■	■	■	■	63
27	One-way flow control valve GRLA	For regulating speed	■	■	■	■	64
28	Push-in fitting QS	For connecting compressed air tubing with standard outside diameter	■	■	■	■	quick star
29	Bellows kit DADB	– Protects the cylinder (piston rod, seal and bearings) against a wide range of media and thus prevents premature wear – The kit can only be used in combination with an extended piston rod (K8)	■	–	■	■	58

1) Not with variant S2 or S20

2) For piston ∅ 32, 40 mm only with variant R3

Standard cylinders DNC, ISO 15552

Technical data

Function

DNC-...

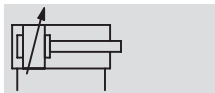
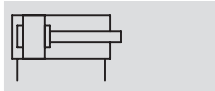

Without position sensing

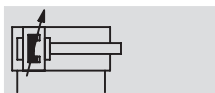
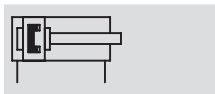

DNC-...-A-...

With position sensing



-  - Diameter
32 ... 125 mm
 -  - Stroke length
10 ... 2,000 mm
 -  - www.festo.com
- Wearing parts kits
→ 22



- Standards-based cylinders to ISO 15552 (corresponds to the withdrawn standards ISO 6431, DIN ISO 6431, VDMA 24 562, NF E 49 003.1 and UNI 10290)



DIN



General technical data							
Piston Ø	32	40	50	63	80	100	125
Pneumatic connection	G $\frac{1}{8}$	G $\frac{1}{4}$	G $\frac{1}{4}$	G $\frac{3}{8}$	G $\frac{3}{8}$	G $\frac{1}{2}$	G $\frac{1}{2}$
Piston rod thread	M10x1.25	M12x1.25	M16x1.5	M16x1.5	M20x1.5	M20x1.5	M27x2
	K3	M6	M8	M10	M12	M12	M16
	K5	M10	M12	M16	M20	M20	M27
Constructional design	Piston						
	Piston rod						
	Profile barrel						
Max. torsional backlash of piston rod [°]	Q ±0.65	±0.6	±0.45	±0.45	±0.45	±0.45	-
Cushioning	Flexible cushioning rings/pads at both ends						
	Pneumatic cushioning, adjustable at both ends						
Cushioning length PPV [mm]	20	20	22	22	32	32	42
Position sensing	Via proximity sensor						
Type of mounting	Via female thread						
	Via accessories						
Mounting position	Any						

- | - Note: This product conforms with the ISO 1179-1 standard and the ISO 228-1 standard.

Standard cylinders DNC, ISO 15552

Technical data

Operating and environmental conditions							
Piston Ø	32	40	50	63	80	100	125
Operating medium	Filtered compressed air, lubricated or unlubricated						
Operating pressure [bar]	0.6 ... 12						0.6 ... 10
R8	1.5 ... 12						1.5 ... 10
S11	0.1 ... 12						0.1 ... 10
TT	1 ... 12						-
Ambient temperature ¹⁾ [°C]	-20 ... +80						
S6	0 ... 120						
TT	-40 ... +80						-
Corrosion resistance class CRC ²⁾	2						
R3	3						
Certification	Germanischer Lloyd						

- Note operating range of proximity sensors
- Corrosion resistance class 2 as per Festo standard 940 070
Components subject to moderate corrosion stress. Externally visible parts with primarily decorative surface requirements which are in direct contact with a normal industrial environment or media such as coolants or lubricating agents.
Corrosion resistance class 3 as per Festo standard 940 070
Components requiring higher corrosion resistance. External visible parts in direct contact with industrial atmospheres or media such as solvents and cleaning agents, with a predominantly functional requirement for the surface.

Force [N] and impact energy [J]							
Piston Ø	32	40	50	63	80	100	125
Theoretical force at 6 bar, advancing	483	754	1,178	1,870	3,016	4,712	7,363
S2/S20	415	633	990	1,682	2,721	4,418	6,881
Theoretical force at 6 bar, retracting	415	633	990	1,682	2,721	4,418	6,881
S2/S20	415	633	990	1,682	2,721	4,418	6,881
Max. impact energy at the end positions ¹⁾	0.1	0.2	0.2	0.5	0.9	1.2	5

- The permissible impact energy is reduced by approx. 10% for variants K10 and S20

Permissible impact velocity:

$$v_{perm.} = \sqrt{\frac{2 \times E_{perm.}}{m_{dead} + m_{load}}}$$

$v_{perm.}$ Permissible impact velocity
 $E_{perm.}$ Max. impact energy
 $m_{intrinsic}$ Moving load (drive)
 m_{load} Moving effective load

Maximum permissible load:

$$m_{load} = \frac{2 \times E_{perm.}}{v^2} - m_{dead}$$

 Note
 This data represents the maximum values that can be achieved. The maximum permissible impact energy must be observed.

Standard cylinders DNC, ISO 15552

Technical data

FESTO

Materials

Sectional view

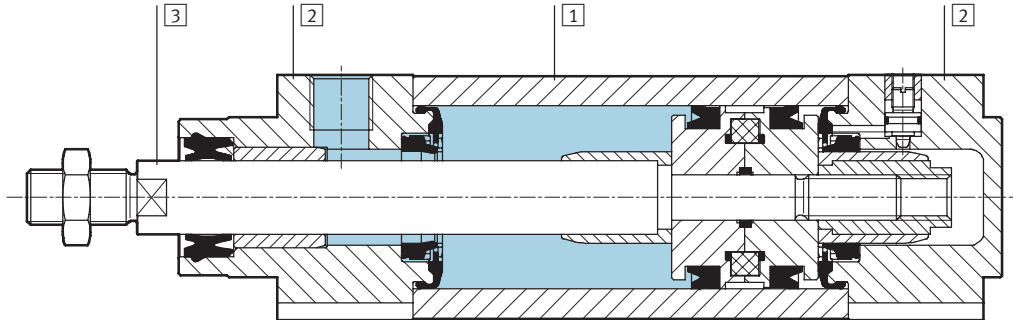

Standard cylinder	Basic version	CT	K10	R3
1 Profile barrel	Wrought aluminium alloy, smooth anodised	Wrought aluminium alloy, anodised	Wrought aluminium alloy, smooth anodised	
2 Bearing and end caps	Die-cast aluminium			
3 Piston rod	High-alloy steel		Wrought aluminium alloy, anodised	High-alloy stainless steel
- Seals	Polyurethane, nitrile rubber			

Standard cylinder	R8	S6	S10	S11	TT
1 Profile barrel	Wrought aluminium alloy, smooth anodised				
2 Bearing and end caps	Die-cast aluminium				Coated aluminium
3 Piston rod	Tempered steel	High-alloy steel			
- Seals	Polyurethane, nitrile rubber	Fluoro rubber			Polyurethane

Standard cylinders DNC, ISO 15552

Technical data

FESTO

Dimensions – Basic version

Download CAD data → www.festo.com

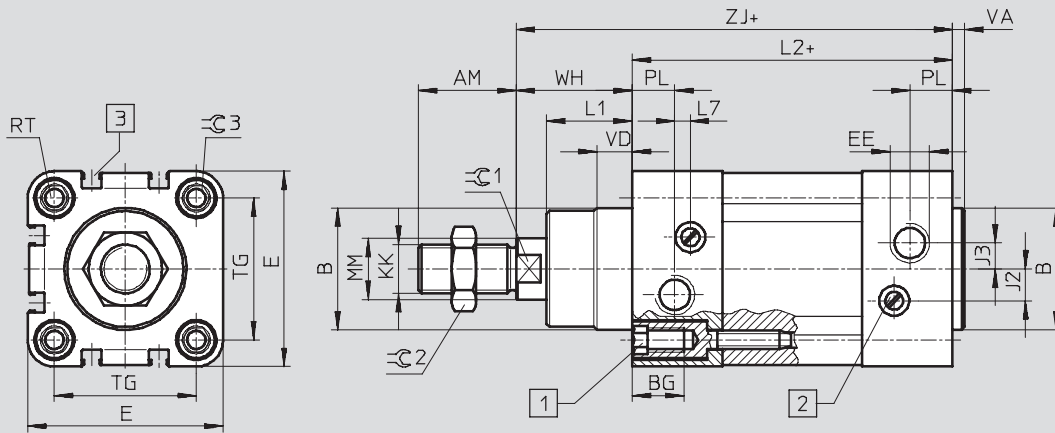

- 1 Socket head screw with female thread for mounting attachments
 2 Regulating screw for adjustable end-position cushioning
 3 Slot for proximity sensor SME/SMT-8
 + = plus stroke length

∅ [mm]	AM	B ∅ d11	BG	E	EE	J2		J3	KK	L1	L2
							TT				
32	22	30	16	45	G $\frac{1}{8}$		6	5.2	M10x1.25	18	94
40	24	35	16	54	G $\frac{1}{4}$		8	6	M12x1.25	21.5	105
50	32	40	17	64	G $\frac{1}{4}$	10.4	11	8.5	M16x1.5	28	106
63	32	45	17	75	G$\frac{3}{8}$		12.4	10	M16x1.5	28.5	121
80	40	45	17	93	G $\frac{3}{8}$		12.5	8	M20x1.5	34.7	128
100	40	55	17	110	G $\frac{1}{2}$		12	10	M20x1.5	38.2	138
125	54	60	22	134	G $\frac{1}{2}$		13	8	M27x2	46	160

∅ [mm]	L7	MM ∅	PL	RT	TG	VA	VD	WH	ZJ	∅C1	∅C2	∅C3
40	3.6	16	14	M6	38	4	10.5	30	135	13	18	6
50	5.1	20	14	M8	46.5	4	11.5	37	143	17	24	8
63	6.6	20	17	M8	56.5	4	15	37	158	17	24	8
80	10.5	25	16.4	M10	72	4	15.7	46	174	22	30	6
100	8	25	18.8	M10	89	4	19.2	51	189	22	30	6
125	14	32	18	M12	110	6	20.5	65	225	27	36	8

Note: This product conforms with the ISO 1179-1 standard and the ISO 228-1 standard.

Standard cylinders DNC, ISO 15552

Technical data

FESTO

Dimensions – Variants

Download CAD data → www.festo.com

K2 – Extended male piston rod thread

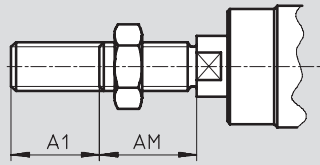

K3 – Female piston rod thread

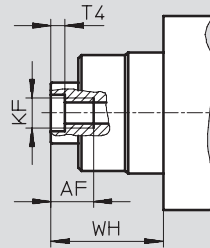

K5 – Special piston rod thread

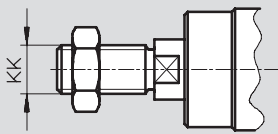

K7 – Piston rod with external hexagon

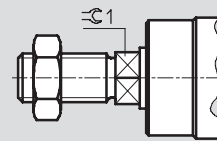

K8 – Extended piston rod

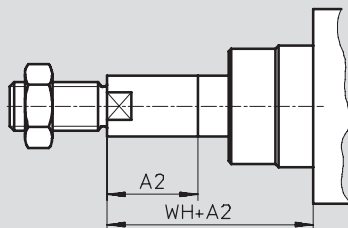

-  - Note

In combination with variant S2/S20, the piston rod is extended at one







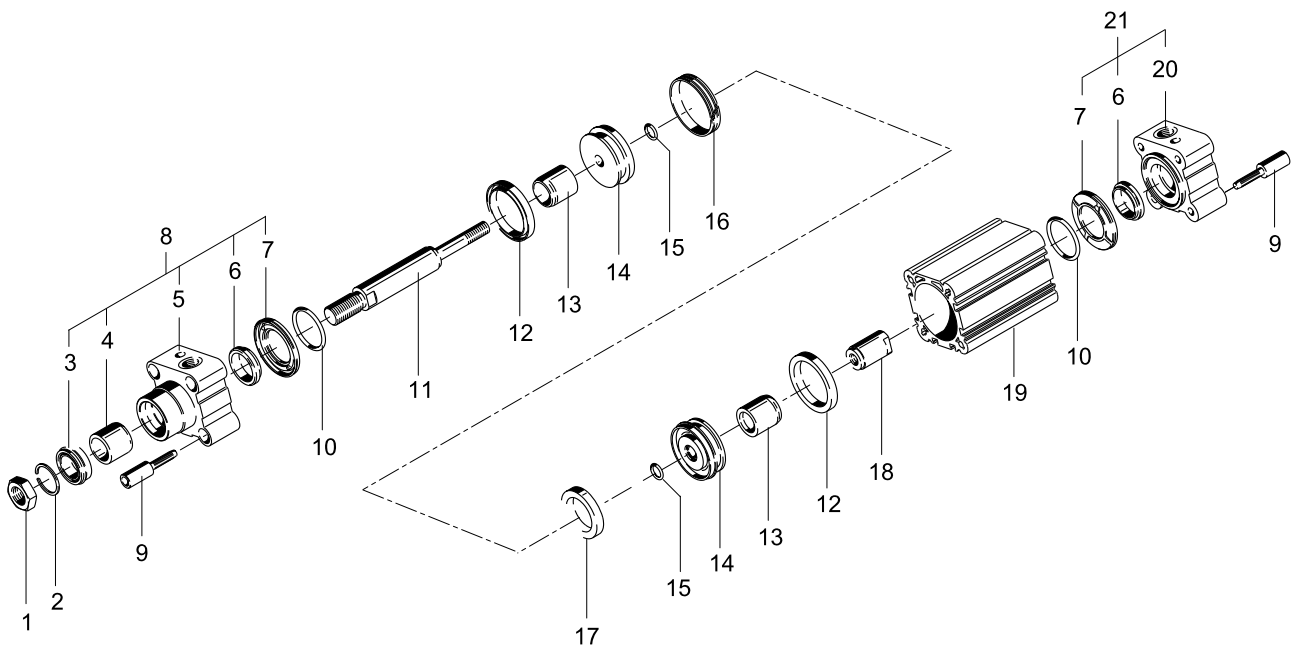



end. In combination with variant Q, the square piston rod is extended.

∅ [mm]	A1 max.	A2 max.	AF	AM	KF	KK		T4	WH	≈1
						Basic thread	Special thread ¹⁾			
32	35	500	12	22	M6	M10x1.25	M10	2.6	26	10
40	35	500	12	24	M8	M12x1.25	M12	3.3	30	13
50	70	500	16	32	M10	M16x1.5	M16	4.7	37	17
63	70	500	16	32	M10	M16x1.5	M16	4.7	37	17
80	70	500	20	40	M12	M20x1.5	M20	6.1	46	22
100	70	500	20	40	M12	M20x1.5	M20	6.1	51	22
125	70	500	32	54	M16	M27x2	M27	8	65	27

1) The special threads are only available as male threads. The mounting nut on the piston rod thread is included in the scope of delivery







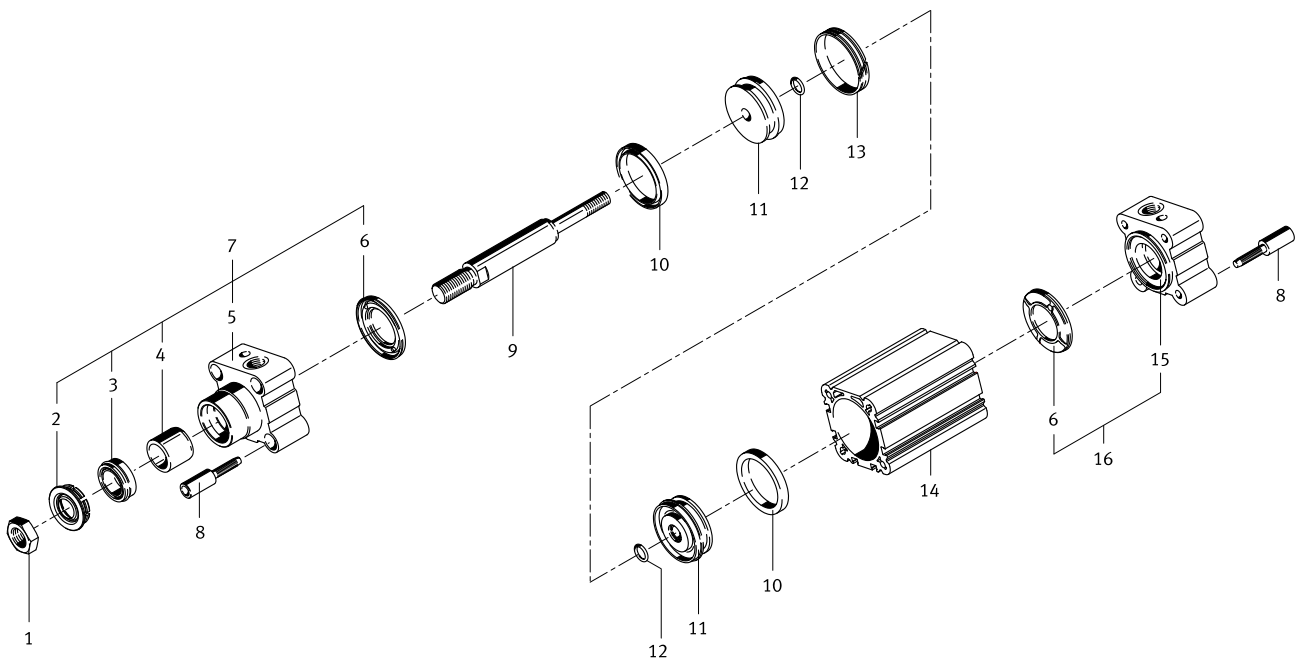







163398 DNC-63- - (Standard cylinder) DNC-63-...-PPV-A-S6

Standard cylinder — DNC-63- - (163398)						
Pos.	Part no.	Type Article designation	Qty.	Unit	Hint	Order
999	384217	DNC- 63- PPVA-S6 Set of wearing parts	1	PC	Spare parts: 3, 6, 7, 10, 12, 15, 16	
1	200127	DIN 439-B-M16X1,5-04 Hex nut	1	PC		
2	223007	DIN 7993-B-30-A2 Circlip	1	PC		
3	210816	20X30X9,5 FKM Rod seal	1	PC	Grease using 329555 LUB-MS6 during assembly	
4		SINT-B50 20X26X23 Bearing	1	PC	Not available separately, see position 8	
5			1	PC	Not available separately, see position 8	
6		25X33 FPM Buffer seal	2	PC	Not available separately, see position 8 / 999 Grease using 329555 LUB-MS6 during assembly	
7	366805	DNC- 63 Cushioning disc	2	PC	Grease using 329555 LUB-MS6 during assembly	
8	371086	DNC- 63-PPV-S6 Bearing cap	1	PC		
9	362533	DNC- 50/63 10.9 Collar screw	8	PC	Use locking compound 247891 LOCTITE-243 Tightening torque 13 Nm	
10		63X 66X2,6/2 F81 Sealing ring	2	PC	Not available separately, see position 999 Grease using 329555 LUB-MS6 during assembly	
11	187785	DNC- 63- - Piston rod	1	PC	When ordering please specify the configuration (see type plate)	
12		63X53X7 75FKM181327 Lip ring	2	PC	Not available separately, see position 999 Grease using 329555 LUB-MS6 during assembly	
13	217694	DN - 50/ 63-PPV Cushion piston	2	PC		
14		DNG- 63- PPVA Piston	2	PC	Not available	
15		12X2-N-FPM80 O-ring DIN3771	2	PC	Not available separately, see position 999 Grease using 329555 LUB-MS6 during assembly	
16		DNN-63-...-A Slip ring	1	PC	Not available separately, see position 999 Grease using 329555 LUB-MS6 during assembly	
17	348578	7X7X156 Magnetic tape	1	PC		
18		DNN-63-PPV Threaded coupling	1	PC	Use locking compound 247891 LOCTITE-243 Tightening torque 45 Nm	
19		DNC- 63- Cylinder barrel	1	PC	Not available Grease using 329555 LUB-MS6 during assembly	
20			1	PC	Not available separately, see position 21	
21	371089	DNC- 63- PPV S6 End cap	1	PC		



163398 DNC-63- - (Standard cylinder) DNC-63-...-P-R8

Standard cylinder — DNC-63- - (163398)						
Pos.	Part no.	Type Article designation	Qty.	Unit	Hint	Order
999	703893	DNC- 63- PPVA -R8 Set of wearing parts	1	PC	Spare parts: 3, 6, 10, 12, 13	
1	200127	DIN 439-B-M16X1,5-04 Hex nut	1	PC		
2	372313	20X6,2X34,2 Scraper	1	PC		
3	203657	20X30X9,5 NBR Rod seal	1	PC	Grease using 397446 LUB-KB2 during assembly	
4		SINT-B50 20X26X23 Bearing	1	PC	Not available separately, see position 7	
5		DNC- 63-PPV Bearing cap	1	PC	Not available separately, see position 7	
6		DIN 7991-M6X35-8.8 Countersunk screw	2	PC	Not available separately, see position 7 / 999 Grease using 397446 LUB-KB2 during assembly	
7	373196	DNC- 63-P-R8 Bearing cap	1	PC		
8	362533	DNC- 50/63 10.9 Collar screw	8	PC	Use locking compound 247891 LOCTITE-243 Tightening torque 13 Nm	
9	187785	DNC- 63- - Piston rod	1	PC	When ordering please specify the configuration (see type plate)	
10		63X53X7 PU Lip ring	2	PC	Not available separately, see position 999 Grease using 397446 LUB-KB2 during assembly	
11		DNG- 63- PPVA Piston	2	PC	Not available	
12		12X2-N-NBR70 O-ring DIN3771	2	PC	Not available separately, see position 999 Grease using 397446 LUB-KB2 during assembly	
13		DNN-63-...-A Slip ring	1	PC	Not available separately, see position 999 Grease using 397446 LUB-KB2 during assembly	
14		DNC- 63- Cylinder barrel	1	PC	When ordering please specify the stroke (see type plate) Grease using 397446 LUB-KB2 during assembly	
15		DNC- 63-PPV End cap	1	PC	Not available separately, see position 16	
16	371466	DNC- 63-P End cap	1	PC		